

A VHF-UHF 3-Band Mobile Antenna

Three bands — 144, 220 and 440 — on one stick sound interesting? This antenna might allow you to condense that stainless-steel and plastic jungle atop your auto onto a single pole.

By J. L. Harris,* WD4KGD

In looking for a mobile antenna system for my Drake UV-3, I rejected the notion of one broadband antenna such as the discone because of band-switching problems not to mention its somewhat busy appearance. I also rejected the idea of three separate whips which I felt would give the relatively small roof area of my pickup truck a cluttered look. Three separate antennas confined to so small a space would also cast "shadows" on the vertical patterns of one another. In order to take full advantage of the three antenna terminals on the UV-3, I needed three separate antennas, but I wanted an omnidirectional pattern with no "holes."

The solution I chose was to use three stub-fed verticals on one whip. The stub-fed vertical, or J antenna, consists of a basic half-wave radiator end fed through a quarter-wave stub. This stub serves as an impedance transformer. It transforms the high impedance of the half-wave radiator to that of the low-impedance coaxial line. Few antennas lend themselves to omnidirectional patterns and ease of matching to coaxial line as well as the stub-fed vertical.

Construction

My approach is cheap, novel and effective and uses only four basic parts except for the coaxial lines: the whip and three easily fabricated blocks. These materials are available at most hardware or hobby stores. The whip is one piece of 3/8-inch (9.5-mm) aluminum tubing 60 inches (152 mm) in length. Be sure that the piece you select is straight and free of nicks or dents.

Overall construction is shown in Fig. 1. The three stub blocks are made from

3/8-inch (9.5-mm) aluminum stock. Refer to Fig. 2 and saw three blocks 3/8 × 5/8 × 1-1/8 inches (9.5 × 15.9 × 28.6 mm). Drill a 3/8-inch (9.5-mm) hole as shown so that the piece will slip over the mast. Tap a no. 6-32 hole into the 3/8-inch (9.5-mm) hole just drilled for a setscrew to hold the block in place. The third hole is used to connect the braid of the coaxial cable to the mast. It is at this point where the quarter-wave stub begins and the feed line ends. For RG-58/U and similar size cable use a 13/64-inch (5.2-mm) drill and tap the hole with 1/4-20 thread. For RG-8/U, use a 25/64-inch (9.9-mm) or "X" drill and tap with 7/16-20 thread. Prepare the coaxial cables by separating the center conductors from the remainder of the cable to the lengths given in Fig. 1. Cut off all but 3/8 inch (9.5 mm) of the braid and fold this back over the jacket. These sections can be threaded into the tapped holes. The blocks can then be mounted to the whip as in Fig. 1.

Matching

As mentioned earlier, the quarter-wave stub is an impedance transformer. The spacing between the coaxial cable center conductor and the whip (dimension "A" in Fig. 1) determines the impedance of this section and consequently the match to 50-ohm line. Using an SWR indicator, determine the optimum spacing "A." This dimension can vary greatly depending on the size of the cable and its dielectric material. Once I determined the correct spacing, I stood off the center conductor from the main support with small styrofoam blocks. Electrical tape was used to hold the quarter-wave section and styrofoam block to the main support.

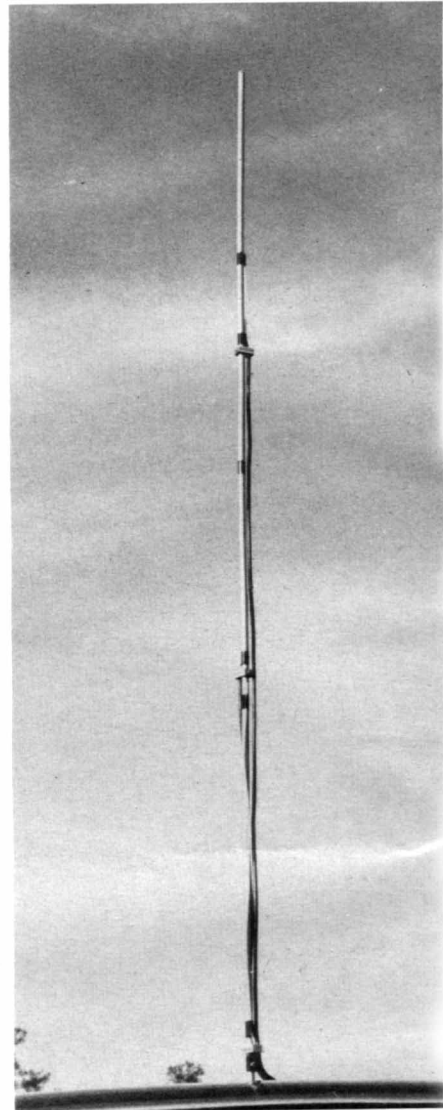

The three-band antenna system mounted atop a pickup truck. (photo by WD4FNS)

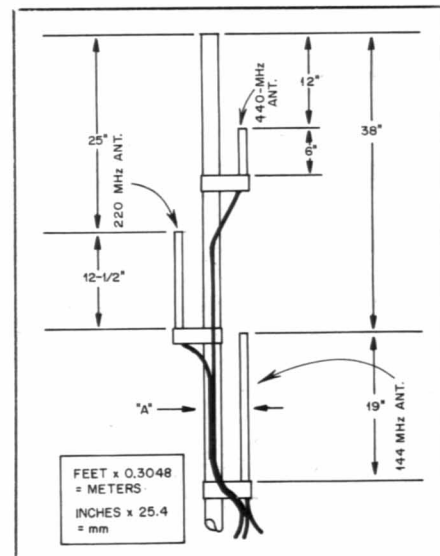

Fig. 1 — Construction dimensions of the three-band antenna. Cables should be routed and taped as shown.

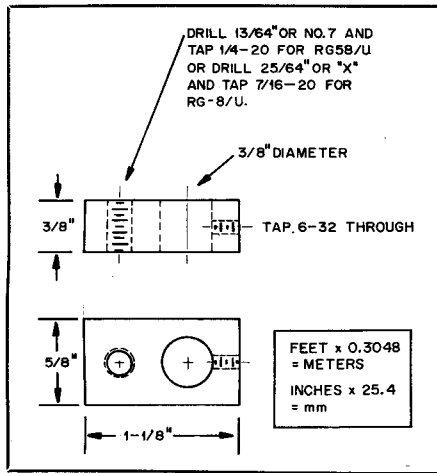

Fig. 2 — Detail drawing of the stub blocks used to connect and support and the quarter-wave sections.

The cables from the 440- and 220-MHz antennas should be routed as shown in Fig. 1 on opposite sides of the main support and away from other stubs.

The assembly is finished by taping all cables in place and coating the stub blocks with clear acrylic spray to prevent moisture from entering the cables. Although this antenna system is intended for mobile use and is constructed for this purpose, it should not be overlooked as a base station system. Just add 6 meters and you've got a 4-band array! E-plane patterns for the three bands are shown in Fig. 3.

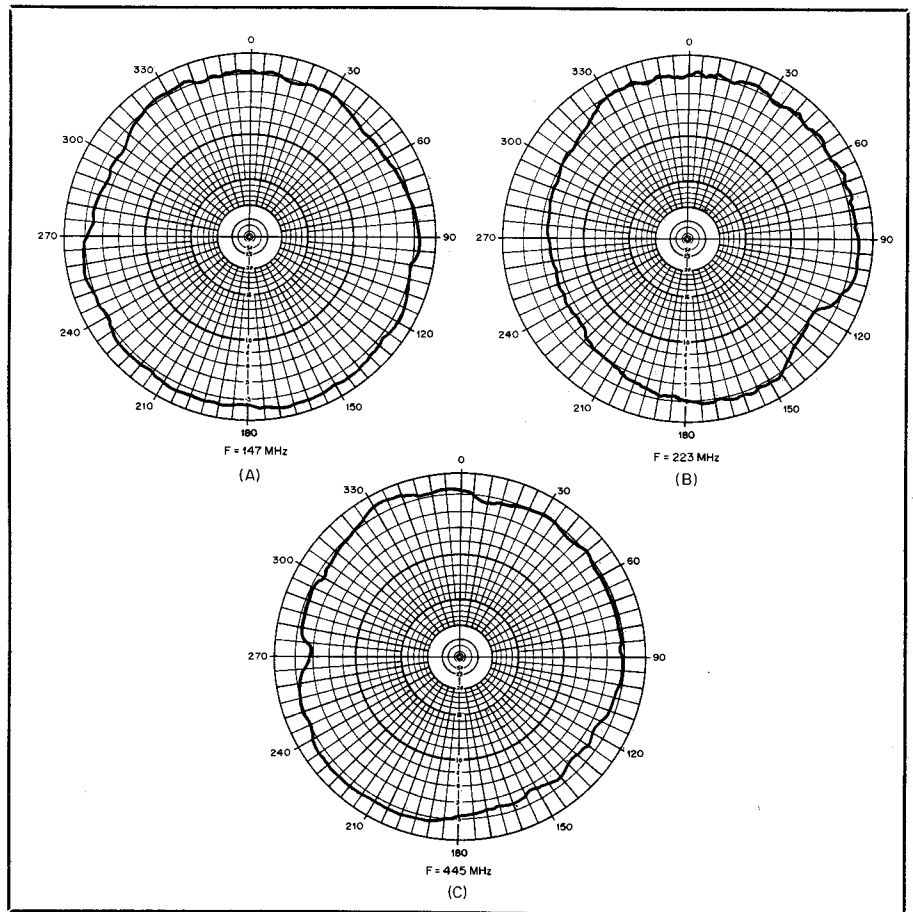

Fig. 3 — E-plane patterns for the three-band antenna. The patterns at A, B and C, respectively, are measured responses for 147, 223 and 445 MHz.

Feedback

□ An omission occurred in "The Microprocessor and Slow-Scan Television," January 1980 *QST*, page 40, Fig. 8A. The box to the right of the "End of Line?" triangle should read "Erase to End of Line."

□ The input intercept figures for the Drake R-7 receiver, "Product Review," January 1980 *QST*, page 49, were reversed. The corrected text should read: "These numbers equate to a 3rd-order input intercept of +17 dBm on 80 meters with the preamp turned off and -2.5 dBm with the preamp turned on."

□ The diagram for W6HPH's two-element, 144-MHz antenna that appeared in "Hints and Kinks," October 1979, *QST*, should have indicated the part for mounting the BNC fitting as a brass bracket.

□ Two SSTV frequencies were left off "The Considerate Operator's Frequency

Guide," January *QST*, page 91. Both 7171 kHz and 21.340 MHz are generally recognized SSTV frequencies. Others are 3845 kHz, and 14.23 and 28.68 MHz.

□ The list labeled "6-Meter Radio Control Channels" ("FM/RPT," December 1979 *QST*, page 77) is actually a list of "guard" channels which could be allocated for repeater use in the event that additional repeater frequencies are needed. It is suggested that frequency coordinators do not assign these channels. Actual R/C channels are 53.1, 53.2, 53.3, 53.4, 53.5, 53.6, 53.7 and 53.8 MHz.

□ The accident involving two Union Pacific Railroad employees ("Stray," January *QST*, page 41), did not occur, according to John Champa, K8OCL, an ARRL technical advisor on safety matters from Columbus, OH. His information was corroborated by a Union Pacific spokesperson. Although butane can be considered dangerous if it is mishandled, Champa reports, it is not nearly as explosive as three sticks of dynamite. The "Stray" item was paraphrased from a club newsletter, which had published an account of the supposed incident.

Strays

CALLING PROFESSIONAL STUDENTS

□ If you have received your acceptance letter from, or are now attending medical, dental, osteopathy, nursing, veterinary or other health-related professional school, you are eligible to join the Medical Amateur Radio Council, Ltd. (MARCO). This group of ham/health professionals meets regularly, on-the-air, to exchange medical and electronic data. Further information and applications from Milt Lowery, N5BLU, Baylor College of Dentistry, 3302 Gaston Ave., Dallas, TX 75246.

QST Congratulates . . .

□ Jack Boyce, WD0GMR, Kansas City, MO, who put the Kansas City Emergency Preparedness Office's radio equipment which had been unused and in storage for several years, back on the air. The four or five afternoons of work, a major donation from any volunteer, is even more significant because Jack is legally blind.